

Subject: DG-30A DG-40A

Date: November 2020

New design leads to increased durability

After more than 10 years of successful production and sales of the demolition grab models DG-30 and DG-40, with some minor and more significant modifications and improvements throughout the years, it is now time to introduce the successor of these models:

NPK® DG-30A / DG-40A



The DG-30A/DG-40A comes with a new style of frame. This frame offers even more stiffness and better protection than before. Dirt and waste will be kept out much more and hydraulic components are even better protected against damage.

Subject: DG-30A DG-40A

Date: November 2020

New Features:

- New redesigned frame (moving cover at the bottom has been deleted)
- Link on DG-30A/DG-40A is straight (on DG-30/DG-40 it was curved)
- Two short Link Pins (on DG-30/DG-40 there is one long Link Pin, which also held the moving cover)
- More bolts to mount the replaceable cutters (8 pieces vs 6 pieces)
- Covers on both sides of frame with "NPK" and "model name"

Features:

- Oversized main pins all combined with wear bushings and sealed with O-rings.
- Powerful hydraulic rotation motor
- Possibility of 2 rotation motors
- No drain line needed
- Hydraulic cylinder with cushion at the end of the stroke (opening)
- Hydraulic side connections
- Easy maintenance
- Easy accessibility to adjustment of rotation speed.
- Pilot check valve against unexpected opening of the arms
- Arms build with Hardox 400
- Frame side plates and bottom plate made of Hardox 400
- Cutters with a hardness of 500HB
- NPK standard bolt pitch
- Strong Bearing (Slewing ring)
- Break valves integrated in hydraulic motor
- High closing force

Specifications:

Model	DG-30A	DG-40A
Excavator weight (t)	18 - 30	25 - 40
Weight (kg)	1850	2050
Capacity (L)	800	900
Working pressure (MPa)	25 - 35	25 - 35
Oil flow (l/min)	80 - 120	80 - 120
Closing force (kN)	72	72
Rotation pressure (MPa)	10 - 14	10 - 14
Rotation oil flow (l/min)	20 - 30	20 - 30
Opening width (mm)	2410	2410
Height (mm)	1485	1485
Width (mm)	1115	1360

Product Info

Subject: DG-30A DG-40A

Date: November 2020

DG-30 DG-40

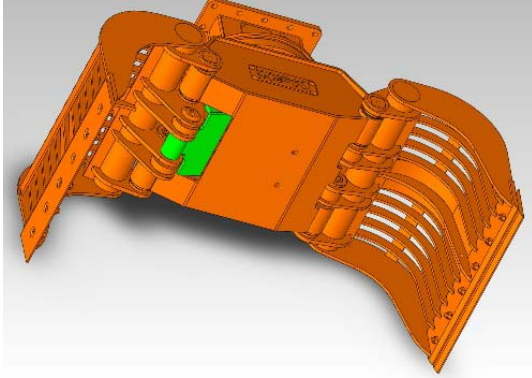

DG-30A DG-40A

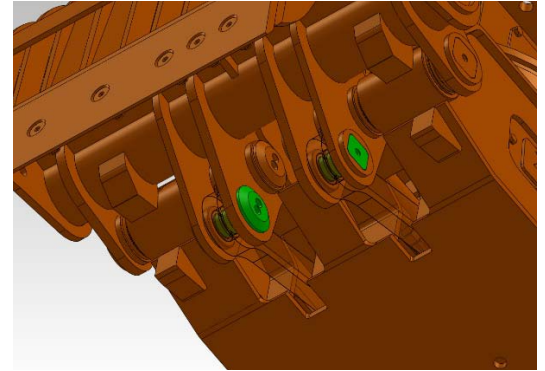
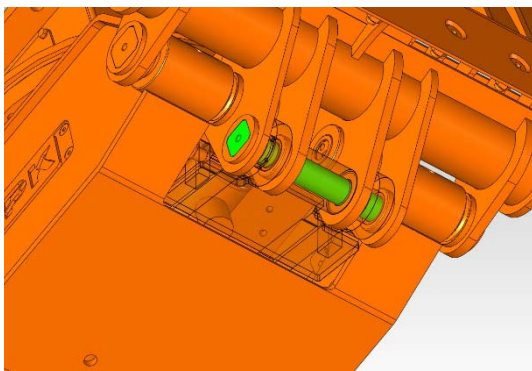
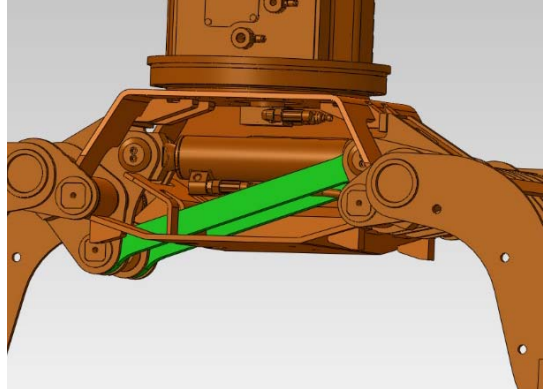
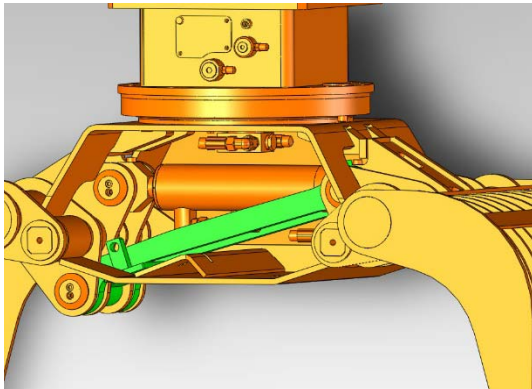
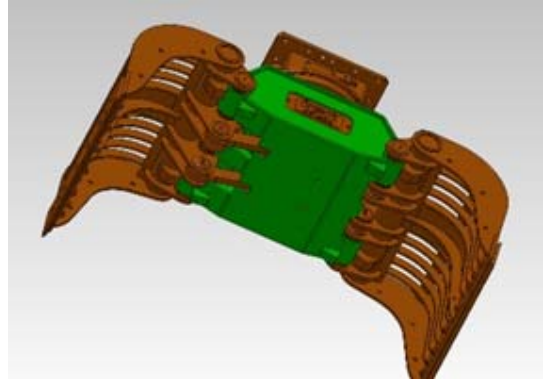

Product Info

Subject: DG-30A DG-40A

Date: November 2020

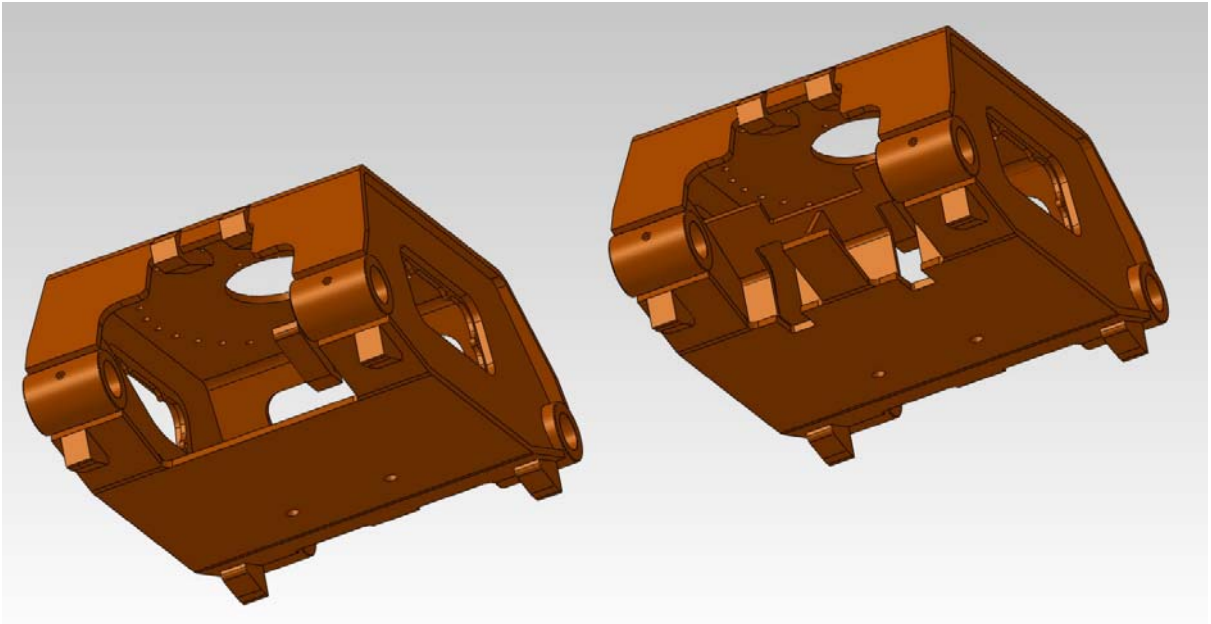
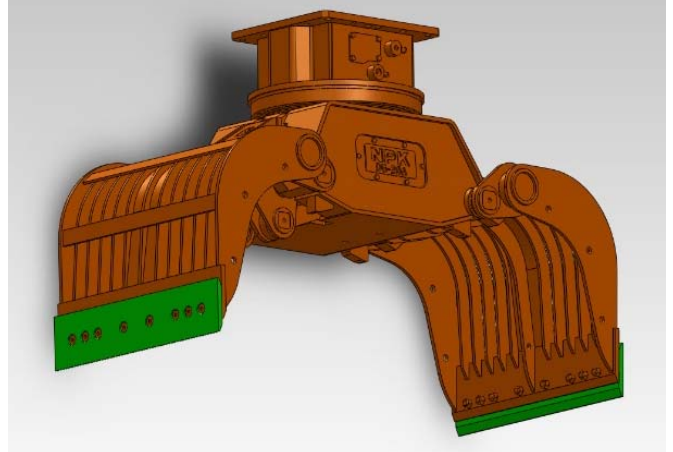
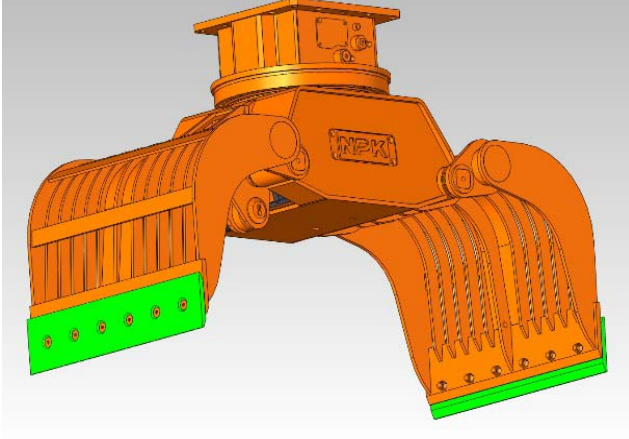

Subject: DG-30A DG-40A

Date: November 2020

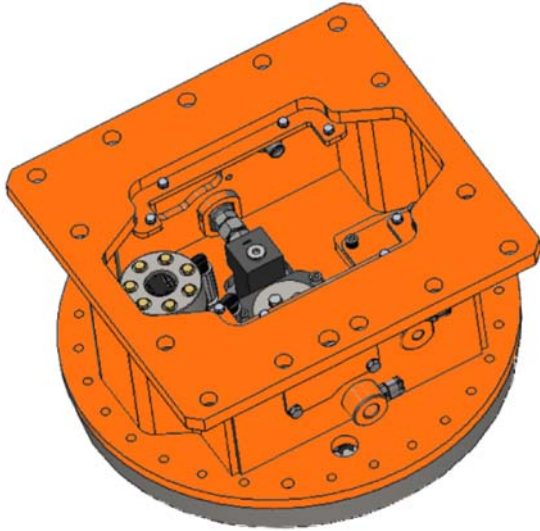
Options:

1 Motor

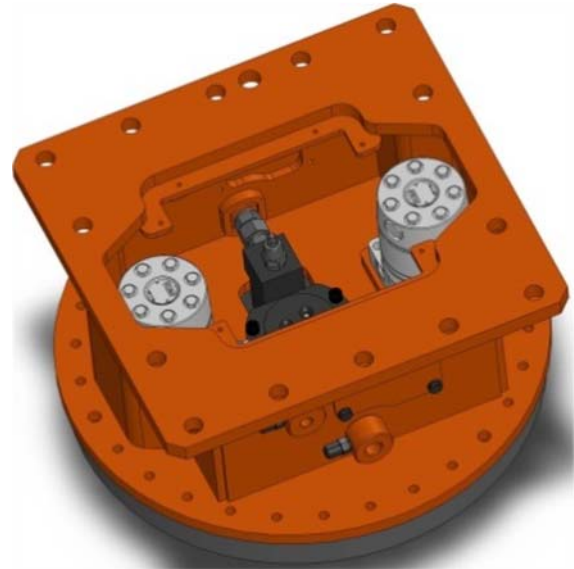

2 Motors

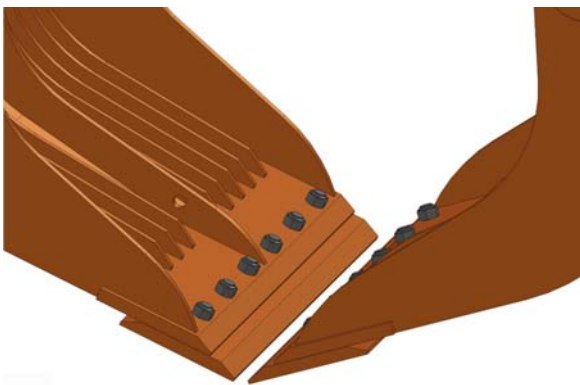

Sharp Edge Cutter

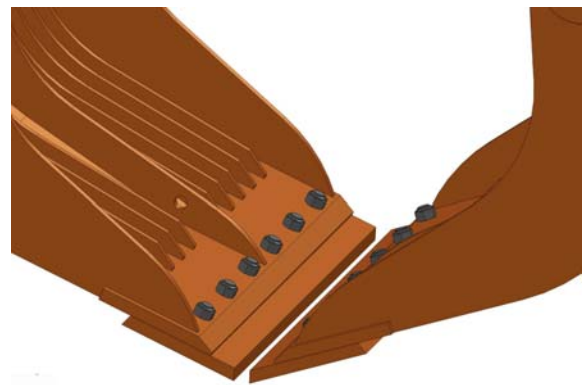

Blunt Edge Cutter

Product Info

Subject: DG-30A DG-40A

Date: November 2020



With Bars



Perforated Plate

AVAILABILITY DG-30A
AVAILABILITY DG-40A

: November 2020
: February 2021

PRICING

: Please contact Robin Prein